



High Performance Building

Dow Performance Silicones

Silicone Structural Glazing Manual

DOWSIL™



Contents

Introduction	4	Compatibility Testing.....	6
Project Review	4	Non-Stain Testing.....	6
Design Review.....	4	Other Laboratory Testing.....	6
Substrate and Material Approval.....	4	Sample Submission.....	6
Product Quality	4	Warranty.....	6
Joint Preparation and Sealant Application.....	4	Project Workflow Diagram	7
Quality Control.....	4	Structural Glazing Design	8
Documentation.....	4	European Technical Approval (ETA).....	8
		European SG Project Checklist Calculator in COOL.....	8
		Structural Glazing Joint Dimensioning	8
		Structural Glazing Joint Dimensioning Guidelines.....	8
		Structural Glazing Terminology	8
		Structural Bite.....	8
		Thickness.....	9
		Windload and Glass Dimension.....	9
		Structural Bite Calculation for Windload and	
		Glass Dimension.....	9
		Thermal Dilatation.....	9
		Glueline Thickness Calculation for Thermal Dilatation.....	9
		Deadload.....	9
		Structural Bite Calculation for Deadload.....	9
		Structural Glazing System Types	10
		4-Sided Structural Glazing.....	10
		2-Sided Structural Glazing.....	10
		Slope Glazing.....	10
		Stepped Glass.....	10
		U-Profile Systems.....	10
		Total Vision Systems.....	10
		Other System Types	11
		Structural Glass Systems.....	11
		Structural Attachment of Non-Glass Materials.....	11
		Protective Glazing.....	11
		Substrates and Materials for Structural	
		Glazing Applications.....	11
		Dow Europe Adhesion/Compatibility Guide.....	11
Dow Product Offering	4		
Structural Glazing Silicone Sealants	4		
DOWSIL™ 993 Structural Glazing Sealant.....	4		
DOWSIL™ 895 Structural Glazing Sealant.....	4		
Insulating Glass Silicone Sealants	4		
DOWSIL™ 3362 Insulating Glass Sealant.....	5		
DOWSIL™ 3793 Insulating Glass Sealant.....	5		
Weatherproofing Sealants	5		
DOWSIL™ 756 SMS Building Sealant.....	5		
DOWSIL™ 791 Silicone Weatherproofing Sealant.....	5		
DOWSIL™ 757 Weatherproofing Sealant.....	5		
Cleaners and Primers	5		
DOWSIL™ R-40 Universal Cleaner.....	5		
DOWSIL™ 3522 Cleaning Solvent Concentrated.....	5		
DOWSIL™ 1200 OS Primer.....	5		
DOWSIL™ Primer-C.....	5		
DOWSIL™ Construction Primer P.....	5		
Project Review	5		
Dow Project Support	5		
Product Recommendation	5		
Design Review	5		
Substrate and Material Approval.....	6		
Adhesion Testing.....	6		

Aluminium Profiles.....	12	Sealant Application and Quality Control Procedures.....	17
Stainless Steel.....	12	Sealant Application Procedure	17
Laminated Glass.....	12	Sealant Cure Requirements.....	17
Coated, Spandrel and Tinted Glass	12	Site Glazing Cure Requirements	17
Self-Cleaning and Easy-to-Clean Glass.....	12	Factory Glazing Cure Requirements.....	17
Gaskets and Rubber Materials	12	Reglazing Procedures.....	17
Product Quality	13	Reglazing Due to Glass Breakage	18
General Considerations	13	Reglazing Due to System Failure.....	18
Material Storage and Handling.....	13	Quality Control Test Procedures	18
Shelf Life.....	13	General Considerations	18
Factory vs. Site Glazing	13	Sealant Production Quality Control.....	19
Joint Preparation and Sealant Application.....	13	Glass Test	19
Quality Control	13	Butterfly Test.....	20
One-Component Sealants.....	13	Snap Time Test	21
Storage Temperature and Conditions	13	Mixing Ratio Test	21
Skin-over Time/Elastomeric Test	13	Adhesion and Cure Quality Control Tests.....	22
Two-Component Sealants.....	14	Peel Adhesion Test	22
Storage Temperature and Conditions	14	H-Piece Test	23
Two-Component Dispensing Equipment Guidelines	14	Deglaze Test	24
Surface Preparation and Sealant Application.....	15	Documentation	24
Substrate Cleaning Procedure	15	Production and Quality Control Audit.....	25
Non-Porous Substrates.....	15	Maintenance and Repair	25
Porous Substrates	15	European SG Project Checklist.....	26
Solvent Consideration	15	SG Project Testing Submission	27
Masking	15	Sealant Production Quality Control Log.....	28
Two-cloth Cleaning Method	16	Sealant Adhesion Quality Control Log	
Substrate Priming Procedure.....	16	(Peel Adhesion Test)	29
Placing the Panel	16	Sealant Cure Quality Control Log	
Site Glazing Considerations	16	(H-Piece Test & Elastomeric Test).....	30
		Sealant Adhesion and Cure Quality Control Log	
		(Deglaze Test).....	31

Introduction

Silicone structural glazing is a method utilizing a silicone adhesive to attach glass, metal, or other panel material to the structure of a building. Windload and other impact loads on the façade are transferred from the glass or panel, through the structural silicone sealant to the structure of the building. The silicone sealant must maintain adhesive and cohesive integrity as the façade is subjected to windload and thermal stresses.

Structural glazing (SG) is a high performance application and not all silicone sealants are suitable for this application. Only silicone sealants which have been developed and tested specifically for structural glazing applications should be used. The DOWSIL™ structural glazing sealants recommended for this application are identified in the next section of this manual. Each DOWSIL™ structural glazing sealant has been granted a “European Technical Approval” (ETA) through independent testing according to the current European structural glazing standard: European Technical Approval Guideline (ETAG 002). The sealants also have a CE mark which indicates conformity to European health, safety and environmental protection legislation.

This manual is intended to give guidance on the proper design and use of DOWSIL™ silicone sealants in structural glazing applications. The recommendations made in this manual are based on the experience of Dow supporting structural glazing projects for over 30 years. Because structural glazing projects differ in building design, environment and customer requirements, this manual cannot address all possible situations. Dow Technical Service Engineers are available to assist you in your specific project needs.

The success of every structural glazing project is dependent on a partnership between the design professional, sealant user and Dow. Successful structural glazing projects contain the following elements:

Project Review

Design Review

Dow must review and approve the structural joint design on every project.

Substrate and Material Approval

Dow must approve all substrates and materials that contact the structural silicone sealant. Specific project testing will be required by Dow in most cases.

Product Quality

Joint Preparation and Sealant Application

Dow joint preparation, sealant handling and sealant application procedures must be completely followed.

Quality Control

Dow quality control procedures must be followed. Dow will assist the sealant user in the development of a comprehensive quality control program.

Documentation

Quality control procedures and results must be documented in an easily retrievable fashion. Quality control log templates are provided in the Documentation section of this manual.

In subsequent sections of this manual, each of these important elements will be discussed in greater detail.

Dow Product Offering

Dow offers a full range of high performance silicone sealants. Each sealant is developed and tested for a specific application and should only be used as intended unless specifically approved by Dow. Specific product information is available at consumer.dow.com/construction.

Structural Glazing Silicone Sealants

The following Dow silicone sealants are offered for structural glazing applications:

DOWSIL™ 993 Structural Glazing Sealant

DOWSIL™ 993 Structural Glazing Sealant is a two-component, fast cure, neutral-curing silicone sealant intended for structural bonding of glass, metal and other panel materials. When compared to conventional one-component silicone sealants, the fast cure properties of DOWSIL™ 993 Structural Glazing Sealant allow increased production of structurally glazed curtainwall units. DOWSIL™ 993 Structural Glazing Sealant is a high modulus sealant with excellent adhesion to a wide range of materials. DOWSIL™ 993 Structural Glazing Sealant has been granted a “European Technical Approval” (ETA) based on independent testing in accordance with the current European structural glazing guideline ETAG-002. The product has been granted a CE-label based on this approval.

DOWSIL™ 895 Structural Glazing Sealant

DOWSIL™ 895 Structural Glazing Sealant is a one-component, neutral-curing silicone sealant intended for structural bonding of glass, metal and other materials. DOWSIL™ 895 Structural Glazing Sealant is a high modulus sealant with excellent adhesion to a wide range of materials. DOWSIL™ 895 Structural Glazing Sealant has been granted a “European Technical Approval” (ETA) based on independent testing in accordance with the current European structural glazing guideline ETAG-002. The product has been granted a CE-label based on this approval.

Insulating Glass Silicone Sealants

The following DOWSIL™ Silicone Sealants are offered for insulating glass applications. DOWSIL™ Insulating Glass Silicone Sealants are recommended for insulating glass units which are structurally glazed with DOWSIL™ Structural Glazing Silicone Sealants. DOWSIL Insulating Glass Silicone Sealants are designed and intended for insulating glass applications only and should never be used as structural glazing adhesives. For more information on the proper use of silicone sealants in insulating glass applications, please refer to the “Dow Insulating Glass Manual” which is available at consumer.dow.com/construction.

DOWSIL™ 3362 Insulating Glass Sealant

DOWSIL™ 3362 Insulating Glass Sealant is a two-component, fast cure, neutral-curing silicone sealant intended for use as a secondary seal in dual glazed insulating glass units. DOWSIL™ 3362 Insulating Glass Sealant has been granted a “European Technical Approval” (ETA) based on independent testing in accordance with the current European structural glazing guideline ETAG-002. The product has been granted a CE-label based on this approval.

DOWSIL™ 3793 Insulating Glass Sealant

DOWSIL™ 3793 Insulating Glass Sealant is a one-component, neutral-curing silicone sealant intended for use as a secondary seal in dual glazed insulating glass units.

Weatherproofing Sealants

Dow offers a full line of high performance sealants for weatherproofing applications. Following is a brief description of DOWSIL™ Weatherproofing Sealants. These sealants are designed and intended to weatherseal building joints and should never be used as structural glazing adhesives. For more information on the proper use of silicone sealants in weatherproofing applications, please refer to the “Dow Building Envelope Weatherproofing Manual” which is available at consumer.dow.com/construction.

DOWSIL™ 756 SMS Building Sealant

DOWSIL™ 756 SMS Building Sealant is a one-component, low modulus, and neutral-curing silicone sealant designed specifically for weathersealing of sensitive substrates such as natural stone and aluminium panels systems where the aesthetic performance of the sealant is important. This sealant is designed to be non-staining on natural stone and to attract less dirt and atmospheric contaminants than conventional silicone building sealants.

DOWSIL™ 791 Silicone Weatherproofing Sealant

DOWSIL™ 791 Silicone Weatherproofing Sealant is a one-component, low modulus, neutral-curing silicone sealant with a faster skinning time for general weathersealing applications.

DOWSIL™ 757 Weatherproofing Sealant

DOWSIL™ 757 Weatherproofing Sealant is a one-component, low modulus sealant designed for weather sealing of hydrophilic and photocatalytic clean glasses.

Cleaners and Primers

Dow offers a line of cleaners and primers that are developed specifically for use with Dow sealants. In some instances, a specific cleaner or primer will be required for the silicone sealant to achieve optimal adhesion to a specific substrate. For general substrate cleaning and priming recommendations, please refer to the “Dow Europe Adhesion/Compatibility Guide” which is available at consumer.dow.com/construction.

DOWSIL™ R-40 Universal Cleaner

DOWSIL™ R-40 Universal Cleaner is a specially formulated solvent blend designed to clean glass and metal profiles used in structural glazing applications.

DOWSIL™ 3522 Cleaning Solvent Concentrated

DOWSIL™ 3522 Cleaning Solvent Concentrated is a cleaner designed for the solvent purging of two-component meter mix equipment used in structural glazing and insulating glass production. This product does not contain halogenated solvent and has been specifically developed to digest cured silicone sealant present in equipment hoses and mixers.

DOWSIL™ 1200 OS Primer

DOWSIL™ 1200 OS Primer is a one-part chemical treatment primer designed for use with Dow sealants in a variety of applications.

DOWSIL™ Primer-C

DOWSIL™ Primer-C is a one-part chemical treatment primer designed for painted and plastic surfaces to promote sealant adhesion development.

DOWSIL™ Construction Primer P

DOWSIL™ Construction Primer P is a one-part film forming primer designed for use on porous substrates in weathersealing applications.

Project Review

Dow Project Support

Dow professionals are available to assist you with questions about the design and proper use of DOWSIL™ Structural Glazing Sealants for your project. All structural glazing projects must be reviewed and approved by Dow on a project-by-project basis. Only through completion of the procedures recommended in this manual will Dow issue a Structural Adhesion Limited Warranty for your project. For an overview of the process steps, please refer to the Dow Project Workflow Diagram later in this section.

Product Recommendation

Dow will make a project specific product recommendation once the following steps have been taken:

Design Review

Dow must review the structural glazing joint design for every project. A European SG Project Checklist should be completed for each project. A joint dimensioning calculator and SG Project Checklist are available at Dow COOL which can be accessed through Dow's website: consumer.dow.com/construction. Please contact your local Dow Construction Office for more information. A European SG Project Checklist is provided in the Documentation section of this manual.

Dow must review a detail of each SG joint dimensioning. If a standard aluminium profile manufacturer system is used, the system name alone can be provided. Dow has access to the design details of most common profile manufacturers.

All non-standard SG joint designs must be provided electronically using .jpeg, .pdf, .doc, .dwg or .tiff formats to emeai.cool@dow.com.

Dow will review your SG Project Checklist and SG joint dimensioning within three (3) working days if provided electronically and in the manner described above.

Substrate and Material Approval

Dow must approve all substrates and materials which contact the structural silicone sealant. In some instances, materials may be tested through the system or component supplier and project specific testing is not required for approval. For current recommendations please refer to the Dow Europe Adhesion/Compatibility Guide which is available at consumer.dow.com/construction.

Adhesion Testing

Sealant adhesion is one of the most critical components of a successful structural glazing project. Dow must approve every substrate before any sealant application occurs. Dow will typically require that representative samples of each substrate (aluminium profile, enameled glass, coated glass, etc.) be provided to the Dow Sealant Testing Laboratory for adhesion testing. A “representative” substrate sample should be produced in a manner identical to substrates used in the actual structural glazing production. It is the responsibility of the SG applicator to ensure that representative samples are sent to Dow for testing. Upon completion of testing, Dow will provide a written product recommendation, surface preparation and priming recommendations. Testing takes four (4) weeks from receipt of samples.

Compatibility Testing

Incompatible glazing accessories may cause sealant discoloration and/or sealant adhesion loss. Dow must approve all glazing accessory materials before any sealant application occurs. Dow will typically require that representative samples of each material (gaskets, spacers, backer materials, setting blocks, etc.) be provided to the Dow Sealant Testing Laboratory for compatibility testing. It is the responsibility of the SG applicator to ensure that representative samples are sent to Dow for testing. Upon completion of testing, Dow will provide a written product recommendation. Testing takes four (4) weeks from receipt of samples.

Non-Stain Testing

Dow will test all porous substrates to determine if its sealants will cause staining resulting from the migration of fluids into the substrate. Dow will require that a representative sample of the porous substrate (granite, marble, limestone or sandstone) be provided to the Dow Sealant Testing Laboratory for non-stain testing. Upon completion of testing, Dow will provide a written product recommendation. Testing takes six (6) weeks from receipt of samples.

Other Laboratory Testing

Dow may provide non-standard testing such as analytical testing or H-piece testing of production samples. In such cases, a service fee may be charged. Prior to beginning the project, please contact your local Dow Construction Office for a service fee schedule.

Sample Submission

For prompt processing of all testing requests, enter materials for testing through Dow COOL System (COOL) which can be accessed through Dow's website consumer.dow.com/construction. Please contact your local Dow Construction Office for more information. A Structural Glazing Project Testing Submission Form is available in the Documentation section of this manual. Testing samples should be sent to the following location:

Dow Silicones Belgium S.P.R.L
Attention: Sealants Testing Lab
rue Jules Bordet, parc industriel zone C
7180 Seneffe, Belgium

Warranty

Dow offers a project specific Structural Adhesion Limited Warranty for projects using either DOWSIL™ 993 Structural Glazing Sealant or DOWSIL™ 895 Structural Glazing Sealant. Please contact your Dow Construction Office for more information on the warranties available. To obtain a warranty, the following steps must be completed:

1. Dow must approve in writing all materials which contact the DOWSIL™ Structural Glazing Sealant for adhesion and compatibility
2. Dow must approve in writing the structural glazing joint design
3. All daily quality control logs must be submitted and approved by Dow.
4. The sealant user must request the warranty through Dow COOL.

Project Workflow Diagram

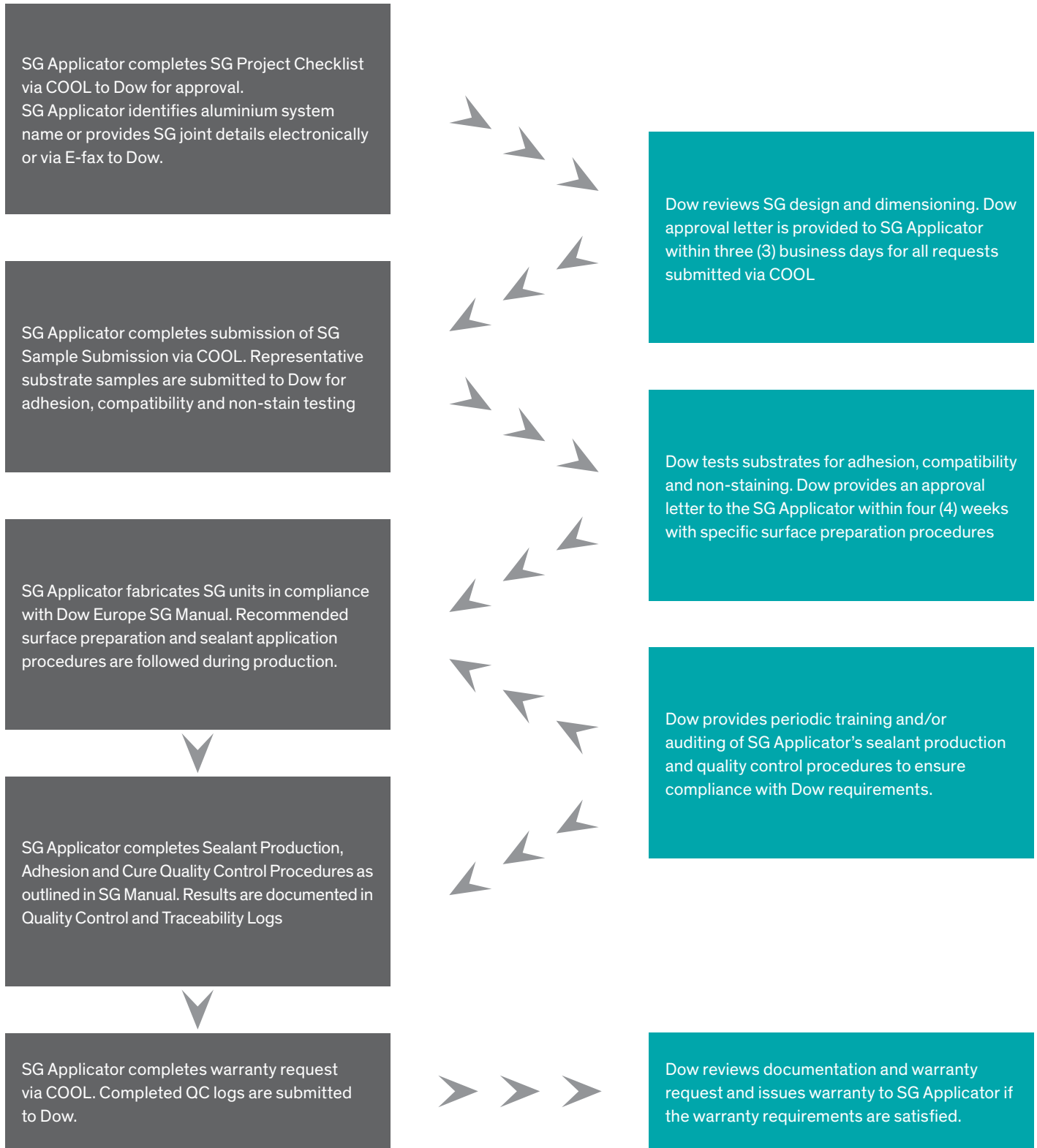

Structural Glazing Design

Guidelines for the design of structural glazing joints are provided in this section. The guidelines provided are based on Dow's extensive experience in structural glazing. Not all design variables are reviewed in these guidelines. Dow Technical Service Engineers are available to help the design professional and sealant user in proper SG joint design.

It is the responsibility of the design professional and sealant user to confirm that the information provided to Dow is accurate and complete. Dow will review details and make project recommendations only as they relate to the structural silicone sealant. Other factors beyond the control of the sealant manufacturer, such as performance of the glass or rigidity of the frames, are the responsibility of the systems designer and systems fabricator.

European Technical Approval (ETA)

Dow intends to comply with current European Guidelines as described in relevant European Standards or Technical Guidelines e.g. (ETAG 002 Guidelines for European Technical Approval for Structural Sealant Glazing Systems (SSGS) Part 1.) For situations that fall outside of these guidelines, Dow will make specific project design recommendations. If the systems manufacturer seeks compliance with ETAG 002 or other relevant standards, Dow can provide recommendations on the steps which are necessary to satisfy those guidelines or standards.

European SG Project Checklist Calculator in COOL

Available through Dow's website consumer.dow.com/construction is the project management system called "CONstruction OnLine System" (COOL). Within COOL is a European SG Project Checklist calculator which can be used to calculate and submit an SG joint design for approval from Dow. Design variables such as glass dimension, windload, and glass type are entered into the calculator. The calculator will provide immediate confirmation if the specific design parameters entered comply with Dow SG guidelines. The calculator will also help determine whether a design meets EOTA Guidelines. Once the information is confirmed as "OK", the project parameters can be submitted to Dow for formal approval. A written approval will be provided by Dow within three (3) working days. For more information and access to COOL, please contact your local Dow Construction Office.

Structural Glazing Joint Dimensioning

A structural glazing joint must be properly designed for the sealant to function as intended. If a joint is improperly designed, the sealant stresses may be excessive potentially causing failure. Therefore, all SG joint dimensioning must be approved by Dow.

Structural Glazing Joint Dimensioning Guidelines

Following are guidelines that apply for all Structural Glazing projects. Dow must review and approve all SG joint dimensioning. Any exceptions to these guidelines can only be made by your Dow Technical Service Engineer.

- The minimum structural joint bite shall be as determined by the Structural Bite Calculation for Windload and Glass Dimension.
- The minimum structural joint thickness shall be as determined by the Glueline Thickness Calculation for Thermal Dilatation.
- The minimum structural bite shall be as determined by the Structural Bite Calculation for Deadload.
- The structural bite must be a minimum of 6 mm regardless of other calculations.
- The glueline thickness must be a minimum of 6 mm regardless of other calculations.
- The structural bite must be equal to or greater than the glueline thickness.
- The bite-to-thickness ratio should be between 1:1 and 3:1.
- The SG joint must be able to be filled using standard sealant application procedures.
- The SG joint design must allow the sealant exposure to air so that it can cure and achieve full physical properties.
- The above guidelines are minimum requirements and exclude any application tolerances.

Structural Glazing Terminology

Structural Bite

Structural Bite is the minimum width or contact surface of the silicone sealant on both the glass panel and the frame. The design windload, glass panel dimensions, impact loads, dead load and thermal dilatation stresses must be considered in the determination of the structural bite dimension.

Thickness

Thickness is the distance from the panel to the frame. Proper thickness facilitates the installation of the sealant and allows reduced sealant stress from differential thermal movement between the glass panel and frame. Thickness in a structural silicone joint is often referred to as glueline thickness.

Typical Structural Glazing Detail

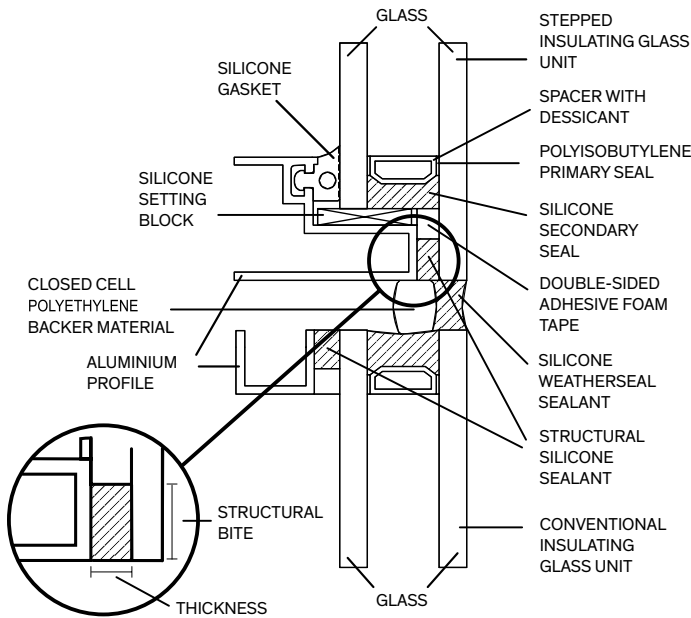

Windload and Glass Dimension

The structural bite requirement is directly proportional to the windload on the building and the dimension of the glass. The higher the windload and the larger the dimensions of the glass are, the greater the amount of structural bite required.

The controlling variables which affect the structural bite requirement are the maximum short span dimension of glass and the design windload that the structural glazing system must be designed to accommodate.

Structural Bite Calculation for Windload and Glass Dimension

$$\text{Minimum Structural Bite (m)} = \frac{\text{Glass Short Span Dim. (m)} \times \text{Windload (Pa)} \times 0.5}{140,000 \text{ Pa}}$$

- Glass Short Span Dimension (SSD) is the shorter of the two dimensions of the rectangular glass panel. For example, on a 1.5 m by 2.5 m glass panel, the SSD is 1.5 m.
- Windload is the maximum wind pressure in Pascal for a return period of 10 years based on EUROCODES and local regulations. This value is provided by the design professional to Dow. 1 Pa = 1 N/m²
- 140,000 Pa (0.14 MPa) is the Maximum Allowable Design Stress for both DOWSIL™ 993 Structural Glazing Sealant and DOWSIL™ 895 Structural Glazing Sealant.
- Maximum allowable design stress is based on the Ru,5 value with a safety factor of 6. The Ru,5 value is the probability at 75% that 95% of the population will have a breaking strength above this value

Thermal Dilatation

The differential thermal movement between the glass and frame will impose upon the structural sealant joint a shear stress that must be considered during the design of the SG joint. The amount of differential movement will depend on the glass and metal (aluminium or stainless steel), maximum temperature change and design of the SG system. There will be greater movement if the aluminium frame is exposed to the exterior.

Glueline Thickness Calculation for Thermal Dilatation

$$\text{Minimum Glueline Thickness (m)} = \frac{\text{Thermal Dilatation (m)} \times \text{E Young (Pa)}}{3 \times \text{Max Allowed Stress in Shear}}$$

- Thermal Dilatation is the amplitude of differential thermal movement between the glass and frame.
- E Young is Young modulus as determined by Dow. DOWSIL™ 993 Structural Glazing Sealant has a Young modulus of 1.4 MPa and DOWSIL™ 895 Structural Glazing Sealant has a Young modulus of 0.9 MPa.
- The Maximum Allowed Stress in Shear is determined by Ru,5 value as determined in shear. For DOWSIL™ 993 Structural Glazing Sealant this value is 105,000 Pa. For DOWSIL™ 895 Structural Glazing Sealant the value is 140,000 Pa.

Deadload

In unsupported SG designs, the deadload weight of the panel is supported by the structural silicone joint. This situation commonly occurs when structural glazing is used on monolithic glass. DOWSIL™ Structural Glazing Silicone Sealants can support the weight of the glass provided stresses do not exceed the allowed design stress for deadload.

Provided the horizontal frame members are as rigid as the vertical members, Dow will consider both the vertical and horizontal or long edges of the frame in the deadload calculation. If the horizontal frame members will not support the glass under windload, only consider the vertical frame members in the calculation.

Structural Bite Calculation for Deadload

$$\text{Min. Bite (m)} = \frac{2,500 \text{ kg/m}^3 \times 9.81 \text{ m/s}^2 \times \text{Glass Thickness (m)} \times \text{Glass Dim (m)}^2}{[2 \times \text{Height (m)} + 2 \times \text{Width (m)}] \times \text{Allowable Design Stress for DL}}$$

- 2,500 kg/m³ is the specific mass of float glass corresponding to approximately 25,000 N/m³ of specific weight
- 9.81 m/s² is a factor for gravity
- The Allowable Design Stress for Deadload (DL) for DOWSIL™ 993 Structural Glazing Sealant is 11,000 Pa. The Allowable Design Stress for Deadload for DOWSIL™ 895 Structural Glazing Sealant is 7,000 Pa.
- If calculation should be compliant with ETAG002 or if the horizontal frame members will not be supporting the glass or will deflect under the deadload of the glass, just consider 2x Height (m) in the denominator of the calculation.

Structural Glazing System Types

There are many different types of structural glazing systems available. Common to all of these systems is that structural silicone sealant is used to structurally attach glass or another material to the building structure. Some of the more common types of systems are discussed in this section.

4-Sided Structural Glazing

4-sided structural glazing is the most common and usually most cost efficient type of structural glazing system used in European countries. Glass is supported on all four edges of the glass with structural silicone. 4-sided SG systems are typically fabricated in a production facility and erected at a jobsite.

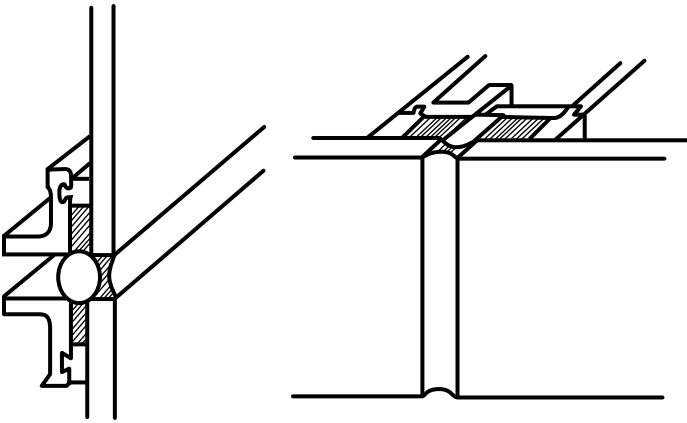

2-Sided Structural Glazing

2-sided structural glazing systems use structural silicone on two of the four sides of the glass. The other two sides of the glass are either mechanically supported or are not structurally supported by a frame. 2-Sided SG systems are fabricated in a production facility or at the jobsite.

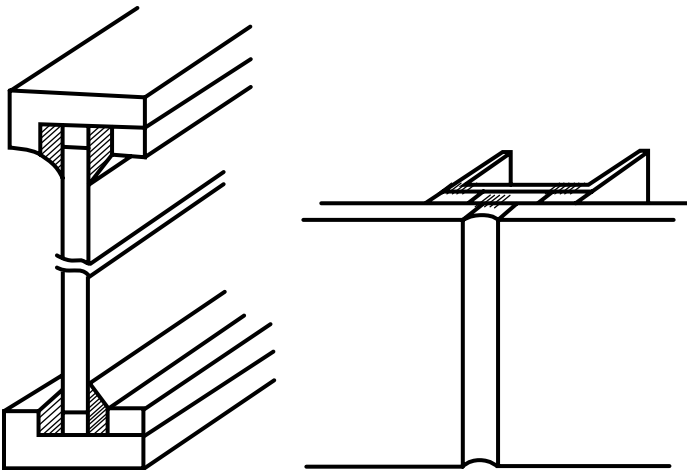

Slope Glazing

Slope glazing is when structural glazing is applied on a façade that is not vertical. Typical slope glazed SG systems are skylights. In such cases, the weight of the glass is considered in the SG joint dimensioning calculations. For slope glazing applications, European regulations require the use of laminated safety glass. Inverted slope glazing has also been used successfully on numerous projects.

Stepped Glass

Many SG systems install the SG joint on the internal surface of the outboard pane. In these systems, the insulating glass units are produced in a step fashion which allows glazing to the outboard pane. More traditional SG systems install the structural joint to the internal surface of the inboard pane of the insulating glass unit. Please refer to “Typical Structural Glazing Detail” on page 9 for an example of a typical stepped glass SG system.

U-Profile Channel Systems

There are many proprietary systems that allow insulating glass units to be attached mechanically to the structure by a U-profile in the cavity between the two panes of glass. Depending on the nature of the system, the silicone sealant may or may not be performing as a structural glazing sealant in the design. These unique systems must be approved by Dow Technical Service Engineers on a system specific basis.

Total Vision Systems

Total vision systems, which are commonly used at the front of a building to maximize vision area, use a glass fin to structurally support the vision glass. In such cases, the 2-sided SG system may use the structural silicone in shear from the glass edge to the glass fin. Dow permits shear beads to perform structurally provided they are independent of a tension bead.



Other System Types

Structural Glass Systems

Structural Glass Systems, often called “Spider Systems” or “Bolted Systems”, have been used on many high profile buildings. Holes are typically drilled in each corner of each glass pane and the glass is attached mechanically with stainless steel “spiders”. These systems are not structural glazing although they have a similar appearance from the exterior. In certain designs, the “spider” only attaches to the internal pane of an insulating glass unit. In such designs, the insulating glass sealant will have a structural function. In all types of Structural Glass Systems, silicone sealants play an important role in maintaining a watertight weatherseal and in the performance of the insulating glass units.

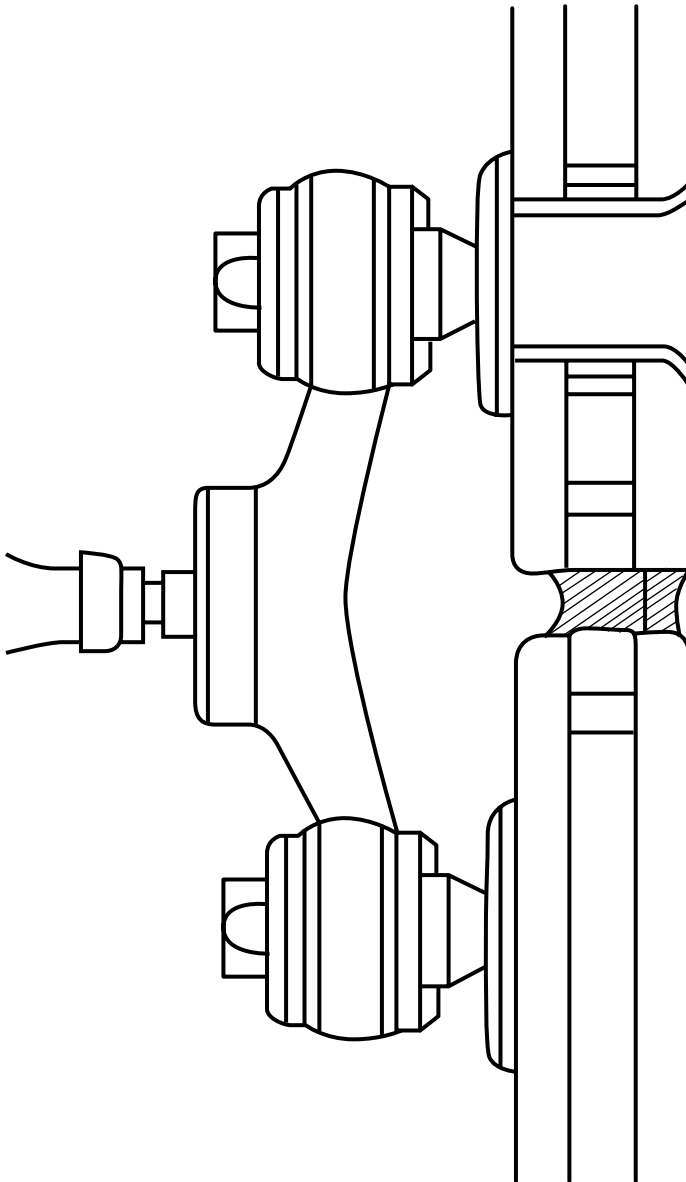

Structural Attachment of Non-Glass Materials

Structural silicone sealant can be used to attach materials other than glass. Dow must test and approve these materials on a material specific basis. Examples of such materials include aluminium composite materials, metal panels and epoxy-backed thin stone panels.

Protective Glazing

Structural silicone sealants are commonly used in window systems which are designed to mitigate the effects of bomb blasts or storms. In some cases, these systems are also structurally glazed. The use of structural glazing in bomb blast protective window designs is appropriate and has been done successfully on numerous projects. In these designs, the sealant is only one element of a complex glazing system which includes the frame, glass and laminate. The structural silicone sealant plays an important role by “anchoring” the laminate glass in the frame during a bomb blast or missile impact. Due to the unique physical and chemical properties of silicone (i.e. viscoelastic properties, long term adhesion and durability) which organic sealants do not provide, high performance structural silicone sealants are the material of choice for these applications. For assistance in protective glazing designs, please contact your Dow Technical Service Engineer.

Substrates and Materials for Structural Glazing Applications

It is important in the design of an SG system that the proper materials be used. Although Dow requires approval of substrates and materials on a project by project basis, certain general recommendations can be provided during the design phase of the project.

Dow Europe Adhesion/Compatibility Guide

Available at consumer.dow.com/construction is the Dow Europe Adhesion/Compatibility Guide. This guide summarizes cleaning and priming recommendations for Dow Sealants on a variety of common construction materials. There are also surface preparation recommendations for specific aluminium profile manufacturers and coated, spandrel and tinted glass products. Also included are general and specific compatibility recommendations on laminated glass products, gaskets, tapes and other extrusions. This guide is periodically updated with new materials and recommendations.

Aluminium Profiles

Dow works closely with most of the major aluminium profile manufacturers in Europe to qualify their systems. Dow has an extensive database of adhesion testing to the profiles from these manufacturers. Aluminium profiles, whether anodized or painted with a polyester powder coating (PPC), must be of an architectural grade quality (QUALANOD or QUALICOAT).

Stainless Steel

Stainless Steel has been used successfully as a structural glazing substrate. The stainless steel must be of an architectural grade quality and should be submitted to Dow for adhesion and compatibility testing.

Laminated Glass

Some laminated glass which utilizes polyvinyl butyral (PVB) may delaminate up to 6 mm when in contact with a neutral cure silicone sealant. This phenomenon is only an aesthetic concern and does not affect the performance of laminated glass in structural glazing applications. For specific compatibility results and recommendations, please refer to the Dow Europe Adhesion/Compatibility Guide which is available at consumer.dow.com/construction or contact your laminated glass supplier.

Coated, Spandrel and Tinted Glass

There are many types of coated, spandrel and tinted glass materials available to the systems designer. There are many important considerations for the selection of glass. For more specific recommendations, please refer to the Dow Europe Adhesion/Compatibility Guide or contact your Dow Technical Service Engineer. Following are a few of the general recommendations:

- Soft coating must be completely removed from all glass surfaces to receive structural silicone sealant. These coatings do not provide adequate strength and durability for long term stability of the structural bond. Soft coatings are often very difficult for silicone sealant to adhere to. Residual soft coating on the glass surface may cause sealant adhesion failure initially or after ageing (silver corrosion).
- Hard coatings are acceptable surfaces for structural glazing if these products have demonstrated long term stability and sealant adhesion has been verified through testing by Dow.
- Ceramic enameled spandrel coatings which are baked onto the glass during glass production and which meet required surface quality criteria are acceptable surfaces for structural glazing. Some patterned glasses are difficult to adhere to and must be submitted for laboratory testing by Dow prior to use.
- Tinted glass, like clear float glass, tempered glass and heat strengthened glass, is acceptable for structural glazing. Sandblasted or acid-etched glass may be difficult to adhere to and must be submitted to Dow for testing prior to use.

Self-Cleaning and Easy-to-Clean Glass

These newer glass types provide lower maintenance solutions for the building owner and have grown in popularity in recent years. For current recommendations on these glass types, please ask the glass manufacturer and refer to the Dow Europe Adhesion/Compatibility Guide or contact your Dow Technical Service Engineer.

Gaskets and Rubber Materials

There are many types of rubber materials that are available for use in a window design and some may not be appropriate for structural glazing applications. An incompatible rubber material may be formulated with excessive levels of plasticizers that may leach into the structural silicone and cause discoloration, softening and potentially sealant adhesion loss to a substrate. Dow recommends testing and approval of materials on a project by project basis. Some SG Systems have qualified and pre-tested their specific rubber materials. Historically, certain material types have proven to be appropriate for structural glazing. Following are some general guidelines for gaskets and rubber materials:

- A structural spacer material in direct contact with the structural silicone must be fully compatible. Materials such as silicone extrusions, polyurethane or polyethylene foam tape as well as certain high quality vinyl and PVC materials have been tested and found to be acceptable for this application. 100% silicone polymer extrusions and gaskets provide the best overall compatibility with silicone sealants.
- Gaskets and setting blocks made of neoprene or EPDM typically discolor lighter colored silicone weatherseal sealants. These materials should not be used in full contact with the structural silicone but may have incidental contact without having an impact on the performance of the sealant. Project specific compatibility testing will determine the suitability of these materials for the application.
- Highly plasticized gaskets and extrusions which cause sealant adhesion loss will not be approved for any contact with Dow Structural Silicone Sealants.

Product Quality

Dow performs extensive quality assurance testing in our manufacturing facilities in accordance with ISO 9001 standards. This section of the manual is intended to provide the sealant user with procedures and recommendations for the proper storage, handling, use and quality control of DOWSIL™ Structural Glazing Silicone Sealants. As a sealant user, you must read, understand and closely follow the procedures and recommendations set forth in this section of the manual. If you have questions regarding any of the following procedures or recommendations, please contact your local Dow Construction Office or your Dow Technical Service Engineer prior to using the Dow Sealant.

General Considerations

Material Storage and Handling

Dow Sealants must be stored at the recommended temperature and environment. Excessive temperatures or moisture may cause a sealant to be damaged. Sealant cure, adhesion and physical properties could be harmed if the sealant is not handled and stored properly. The sealant user must understand and follow recommendation on the proper use of dispensing equipment for two-component silicone sealants.

Shelf Life

DOWSIL™ Sealants must be used within their stated shelf life. Sealant that is used beyond its stated shelf life may not cure properly to its full physical properties and must not be used.

Factory vs. Site Glazing

Structural Glazing fabrication may occur in a production facility or at the job site. Two-component structural silicone sealants are typically applied in the controlled environment of a production facility.

One-component structural silicone sealants may be used in a production facility environment or at the job site. All parties involved with a project, including the architect, engineer and control bodies must support site glazing for a specific project. Specific local requirements may not permit site glazing in some instances. Cure requirements and considerations for site glazing are discussed later in this section.

Joint Preparation and Sealant Application

Specific procedures and recommendations on joint preparation and sealant application are made later in this section. These procedures and recommendations will help to ensure proper sealant adhesion, cure and joint fill. Ignoring or skipping a step in the process could have an adverse effect on the performance of the structural silicone. These procedures should be understood and completely followed by the sealant user.

Quality Control

A comprehensive Quality Control program is the most critical element of a successful structural glazing project. Dow provides procedures and recommendations that must be completely understood and followed by the sealant user. These procedures are proven to be effective and reliable. In the Documentation section of this manual, Dow provides quality

control logs which can be used by the sealant user. Dow will assist you in the development of a comprehensive quality control program. Dow will also audit a production facility and make recommendations for improvement if necessary. Later in this section is a best practices guide for SG production facilities.

One-Component Sealants

Storage Temperature and Conditions

DOWSIL™ 895 Structural Glazing Sealant must be stored at temperatures below +30°C. An expiry date is clearly marked on the product packaging. Sealant should only be used if it is within the expiry date shown on the package. The sealant should be kept in its original unopened package until the sealant is to be used. Sealant should be stored indoors in a dry environment.

Skin-over Time/Elastomeric Test

A skin-over time and elastomeric test should be performed once per day and on each new lot of sealant to be used. The purpose of this test is to ensure that the sealant cures fully and has typical elastomeric properties. Any variation such as excessively long skin-over time may indicate that the sealant is out of shelf life or has been stored at excessively high temperature. Skin-over time will vary with temperature and humidity. Higher temperature and higher humidity will cause the sealant to skin-over and cure faster.

The following procedure must be performed before any material is used in production. Production quality control procedures, such as adhesion tests on production materials, are described later in this section.

1. Spread a 2 mm thick layer of sealant on a polyethylene sheet.
2. Every few minutes, touch the sealant film lightly with your finger
3. When the sealant no longer adheres to your finger, the skin-over time has been reached. If the skin-over time is greater than 2 hours, do not use this material and contact your Dow Construction Office.
4. Allow the sealant to cure for 48 hours. After 48 hours, remove the sealant from the polyethylene sheet. Stretch the sealant slowly to determine whether it has cured to normal elastomeric properties. A control sample of "good sealant" can be used for comparison. If the sealant has not cured properly, do not use the material and contact your Dow Construction Office.
5. Record results in your Quality Control log. A sample Quality Control log is available in the Documentation section of this manual. The completed log should be retained and be available for review by Dow upon request.

Two-Component Sealants

Storage Temperature and Conditions

DOWSIL™ 993 Structural Glazing Sealant must be stored at temperatures below +30°C. An expiry date is clearly marked on the product packaging for the curing agent and base. Sealant should only be used if it is within the expiry date shown on the package. The sealant should be kept in its original unopened packages until the sealant is to be used. Sealant should be stored indoors in a dry environment. Containers of curing agent and base are not lot-matched. For practical purposes it is best to use the oldest container of material first.

Two-Component Dispensing Equipment Guidelines

DOWSIL™ 993 Structural Glazing Sealant is a high performance material, which is certificated and approved by official authorities and test institutes for structural glazing applications. Properly applied, the sealant provides excellent long-term adhesion and durability, which is necessary for structural glazing applications.

DOWSIL™ 993 Structural Glazing Sealant requires correct pumping and mixing by the sealant user to achieve its intended performance. State of the art technology for the application of two-component sealants uses a sophisticated pumping, metering and mixing machine with either a dynamic or static mixer. There are several different suppliers for such equipment. The dispensing machines available in the market are all different in design, so therefore Dow strongly recommends that the sealant user follow the guidelines provided by the equipment supplier regarding the proper use and maintenance of the dispensing equipment. In addition to the guidelines from the equipment supplier, Dow recommends that the sealant user understands and complies with the following best practices:

Provide Proper Sealant Storage Conditions

Sealant containers must be stored below the sealant's recommended storage temperature of +30°C. Sealant can be used at temperatures of up to +40°C. If a sealant container is kept in a production facility at a temperature of greater than +30°C for one week, replace the material. Containers should be stored in their original unopened containers.

Maintain Proper Production Facility Temperature

Ambient temperature in the production facility must be between +10°C and +40°C. For best performance, maintain a temperature of between +18°C to +30°C. At colder temperatures, between +10°C and +18°C, cure rate and adhesion development will be slower. In higher temperatures, between +30°C and +40°C, working time will be shorter.

Avoid Excessively High Humidity

In higher relative humidity, the sealant will cure faster and have a shorter working time. Excessively high humidity (>80%) could cause moisture on the substrate surface and adversely affect sealant adhesion. To minimize the damage of moisture

on the individual sealant components, pails and drums must be kept airtight during storage and after being placed on the dispensing equipment. When using a pressure pot, the air inside the drum or pail must be filtered and dried (silica gel filters are recommended).

Curing Agent Must Be Homogeneous

Prior to placing material on the dispensing equipment, the curing agent should be visually inspected and agitated in the pail to ensure homogeneity. Do not incorporate excessive air during mixing of the curing agent. Low and medium viscosity curing agents (Standard & HV) are more likely to show separation and should be mixed prior to use. High viscosity curing agent (HV/GER) does not generally require mixing but it should be checked in all cases before use. It is recommended to mix the curing agent one to three days before the pail needs to be changed to allow the curing agent to de-air.

Properly Maintain Sealant Dispensing Equipment

It is essential that the sealant user establish a quality program that will ensure that the sealant dispensing equipment is functioning properly. Because there are many different manufacturers of dispensing equipment, maintenance requirements will differ. Requirements common to all equipment manufacturers include:

- Sealant must be dispensed free from exposure to air. DOWSIL™ 993 Structural Glazing Sealant must be processed in a closed system free from exposure to air. Air introduced during the change of sealant containers must be completely bled out or flushed out of the system prior to use.
- Regularly inspect and maintain components of the dispensing equipment. Air can be incorporated into the sealant if the pump is defective or gaskets have hardened or are damaged allowing air ingress into the system. When using high pressure pumping equipment with a follower plate system, regularly check the follower plate to ensure that it is moving smoothly and will not be blocked by a damaged drum or pail or by a damaged or brittle gasket. Proper maintenance and cleaning of the mixer helps to ensure properly mixed sealant. Filters and gaskets should be regularly inspected and replaced as necessary.

- Ensure that there is no contamination of sealant components. Sealant must not come in contact with machinery oils from the equipment. Pumps must be checked for tightness and oil should not be used on the follower plates.

When using a solvent such as DOWSIL™ 3522 Cleaning Solvent Concentrated for cleaning of the mixing line, the sealant lines must be completely closed against the solvent lines to avoid contamination of the sealant with solvent. All gaskets must be compatible with the cleaning solvent.

- Regularly maintain gaskets. Some gaskets, especially those in direct contact to the sealant components, could become brittle or will show a volume increase after prolonged exposure. Deteriorated gaskets must be immediately replaced. Please request from your equipment supplier gaskets and other components, which are compatible and recommended for use with DOWSIL™ 993 Structural Glazing Sealant. The equipment supplier should also provide a schedule for regular replacement of gaskets. Please contact your Dow Technical Service Engineer if you need specific recommendations.

Surface Preparation and Sealant Application

Every structural glazing project requires a diligent and thorough procedure to ensure that substrates are properly cleaned prior to sealant application. The following procedures should be followed for every structural glazing application. Further description of the cleaning, priming and placing procedures are included in the subsequent section.

- 1. Inspect** substrates and materials prior to use. The materials used in production must be representative of the materials that were tested and approved by Dow. The substrates, i.e. aluminium profiles, should be in good condition and not damaged by outdoor weathering.
- 2. Clean** substrates as recommended in the Dow written approval for the project. Joint surfaces must always be clean, dry, dust free and frost free. Moisture or contaminants on the surface may have an adverse effect on sealant adhesion to a substrate.
- 3. Prime** the surface to receive sealant if required by the Dow written approval for the project.
- 4. Place** the glass or panel to be glazed. Care must be taken to not contaminate cleaned surface during any phase of production. If contamination occurs, surfaces must be re-cleaned.
- 5. Apply** sealant into the SG joint cavity. The joint must be completely filled with sealant. By “pushing the bead” of sealant into the joint in a continuous manner, air entrapment can be avoided.
- 6. Tool** or strike the sealant joint surface with a tooling device such as a spatula. The sealant must be pushed into the joint with a tool. Scooping excess sealant from the joint is not acceptable tooling. Tooling helps to ensure that the sealant wets out the joint surfaces and completely fills the joint without air entrapment.

- 7. Inspect** the finished SG units. Determine whether the entire SG joints have been properly filled and tooled. Determine whether the SG units are stored in the proper conditions and inspect whether the sealant is curing properly. Ensure that all of the recommended quality control tests are being performed.

Substrate Cleaning Procedure

The key to acceptable sealant adhesion is a clean surface. Following are proven procedures to clean non-porous and porous substrates.

Non-Porous Substrates

Non-porous substrates such as glass and aluminium must be cleaned with a solvent prior to application of sealant. Dow recommends the “two-cloth cleaning method” be used to clean non-porous materials. The “two-cloth cleaning method” is described later in this section. DOWSIL™ R-40 Universal Cleaner is recommended for solvent cleaning of non-porous substrates. Alternate solvents will be considered. If a solvent other than DOWSIL™ R-40 Universal Cleaner is to be used, please identify the selected solvent during completion of the SG Project Testing Form. Dow will test with your specific solvent blend. Pure water, soaps and detergent are not acceptable cleaning agents.

Porous Substrates

Porous substrates such as granite, marble, limestone or concrete absorb liquid and are considered porous. These substrates are used almost exclusively in weatherseal or non-structural applications. For specific recommendations for porous substrates, please refer to the Dow Building Envelope Weatherproofing Manual which is available at consumer.dow.com/construction.

Solvent Consideration

The solvents named in this section are recommended based upon our experience with these products. You should always check with the supplier of the substrate to ensure that the cleaning procedures and solvents are compatible with each substrate.

Masking

If aesthetics are important, surface adjacent to the SG joint can be protected by masking. Prior to sealant installation, a masking tape can be applied to the surface adjacent to the joint. Test the tape prior to use to ensure that it can be easily removed and does not damage the substrate. During application of the tape, do not apply the tape to joint surfaces since residual adhesive from tape may harm sealant adhesion. Immediately after the sealant has been applied and tooled, remove the tape.

Two-cloth Cleaning Method

The “two-cloth cleaning method” is a proven technique to clean non-porous surfaces. The use of one cloth to clean a substrate is not a recommended procedure and is not as effective as two cloths. Clean, soft, absorbent, lint-free cloths must be used. This method consists of cleaning the substrate with a solvent saturated cloth followed by a drying wipe with a separate clean cloth. Following is the procedure described in greater detail:

1. Thoroughly clean all surfaces of loose debris.
2. Pour a small quantity of cleaning solvent into a working container. A clear plastic, solvent-resistant, squeeze bottle works best for this purpose. Do not apply solvent directly from the original container.
3. Wipe the joint surfaces with sufficient force to remove dirt and contaminants.
4. Immediately wipe dry the solvent wet surface of the substrate with a separate clean, dry cloth. The second cloth must wipe the substrate before the solvent has evaporated.
5. Visually inspect the second cloth to determine if contaminants were effectively removed. If the second cloth remains dirty, repeat the “two-cloth cleaning method” until the second cloth remains clean. For each subsequent cleaning, rotate each cloth to a clean portion of the cloth. Do not clean with the dirty portion of the cloth. For best results, replace used and dirty cloths frequently.

Substrate Priming Procedure

DOWSIL™ 1200 OS Primer is commonly the primer recommended for structural glazing applications. The following procedure describes how to properly prime surfaces with DOWSIL™ 1200 OS Primer:

1. Before using, verify that the DOWSIL™ 1200 OS Primer is within its stated shelf life. The primer should be stored below 25°C in its original unopened container. The primer should be clear and water-like in appearance. If the primer is milky white in appearance, do not use the primer. Red colored primer is also available.
2. Joint surface must first be clean and dry. The step of priming should begin within four (4) hours after the cleaning step. If there is a greater time delay, joint surfaces must be recleaned prior to priming.
3. Pour a small amount of primer into a clean, dry container. Do not pour more than a 10 minute supply of primer into the working container. Replace and tighten the cap on the container immediately after dispensing the primer. Excessive exposure of the primer to atmospheric moisture will cause it to deteriorate and turn milky white in the container.

4. Pour a small amount of primer from the working container onto a clean, dry, lint-free cloth and gently wipe a thin film on all joint surfaces requiring primer. Apply only enough primer to wet the surface. Overpriming can cause adhesion loss between the sealant and the substrate. If too much primer is applied, a powdery white film will form on the substrate. Overpriming is not an acceptable practice and should be stopped immediately. Overprimed surfaces must be recleaned and primed in a proper manner.

5. Allow the primer to dry until all of the solvent evaporates. This typically takes from 5 to 30 minutes depending on temperature and humidity.
6. Inspect the surface for dryness and for the appearance of overpriming. A primed non-porous surface will have a slight haze. If red colored primer is used, the primed surfaces will appear red in color. Primed surfaces must be sealed within the next four (4) hours. Any surfaces primed and not sealed within four hours must be recleaned and reprimed before applying sealant.

Placing the Panel

The glass or panel can be placed once the profiles have been cleaned and primed if necessary. The same cleaning and priming procedures should also be performed at the same time to the glass or panel. Care must be taken to not contaminate cleaned and primed surfaces that are to be sealed. Finger prints can cause adhesion loss. Dow recommends the use of powder-free latex gloves to handle glass panels if there is concern about physical contact with the joint surfaces.

Site Glazing Considerations

Most of the substrate cleaning and priming procedures described above apply to both site glazing and factory glazing. Key considerations for structural glazing on site include:

- Sealant must be stored away from excessive heat. Exposure of the sealant to high temperatures would cause the sealant to degrade and cure improperly.

- An application temperature range of +10°C to +40°C is recommended. At lower temperatures, the substrate must be kept free of condensation or moisture. Substrate temperatures in excess of +50°C will adversely affect the cure and adhesion of the sealant to the substrate.
- Because environmental conditions cannot be controlled on a jobsite, joint surfaces must be cleaned and primed and the panels must be placed and sealed in one (1) hour or less.
- Temporary fasteners must be used to keep the SG joint stable during cure of the sealant. DOWSIL™ 895 Structural Glazing Sealant requires 1 to 4 weeks or longer for full cure. Sealant cure rate is influenced by the SG joint geometry, temperature and humidity. Temporary fasteners may only be removed once the sealant has developed full cure and adhesion.
- A comprehensive quality control program which includes the skin-over time, elastomeric test, peel adhesion test, H-piece test and deglaze test must be followed. Dow can assist in the development of a comprehensive quality control program for structural glazing on site.

Sealant Application and Quality Control Procedures

Sealant Application Procedure

Sealant should only be applied in SG joints which have been cleaned and primed by the recommended procedures. Sealant must be applied to clean, dry, dirt-free and frost-free surfaces and the joint surfaces must be primed if recommended by Dow for the specific project. Sealant adhesion may be harmed by an improperly cleaned or primed SG joint. Sealant must also completely fill the SG joint. The performance of the SG system is dependent on having appropriate structural bite. An underfilled SG joint may jeopardize the performance of the SG system.

The following procedures describe the proper procedures to apply sealant:

1. Apply sealant in a continuous operation using an application gun or dispensing equipment. A positive pressure, adequate to fill the entire joint, should be used. By “pushing the bead” of sealant into the joint in a continuous manner, air entrapment can be avoided.
2. Tool the sealant with light pressure before a skin forms on the sealant. This is typically within 5 to 10 minutes.
3. Avoid the use of wet tooling aids such as soaps or solvents during tooling. Dry tooling is recommended. Do not scoop sealant since this does not effectively push sealant into the joint causing the sealant to fully wet out the sides of the joint.
4. If the surface adjacent to the SG joint has been masked, remove the masking at this time.

Sealant Cure Requirements

All silicone sealants whether one-component or two-component require exposure to atmospheric moisture to cure. In a closed container or concealed joint that is not exposed to atmospheric moisture, sealant cure will be slow to nonexistent. Sealant adhesion will only occur if the sealant is allowed to cure to its full physical properties. Please ensure that the tooled sealant joint is fully exposed to the environment.

Site Glazing Cure Requirements

Temporary support of adjoining materials must be used during the cure of structural sealant for site glazing. The SG joint must be static during cure to prevent stress on the sealant as it cures and develops full adhesion and strength. DOWSIL™ 895 Structural Glazing Sealant typically requires 1 to 4 weeks or longer to fully cure depending on the joint geometry, temperature and relative humidity.

Factory Glazing Cure Requirements

DOWSIL™ 895 Structural Glazing Sealant typically requires 1 to 4 weeks or longer to cure in a production facility environment. Cure rate depends on joint geometry, temperature and humidity. The structurally glazed units must not be moved to the jobsite until the sealant has fully cured and it can be demonstrated through quality control testing that the sealant has achieved full adhesion (100% cohesive failure).

DOWSIL™ 993 Structural Glazing Sealant Structural Glazing Silicone Sealant cures in deep section within 3 to 4 hours depending on temperature and humidity. The sealant generally achieves full adhesion (100% cohesive failure) in 1 to 3 days. The structurally glazed units must not be moved to the jobsite until the sealant has fully cured and it can be demonstrated through quality control tests that the sealant has achieved full adhesion (100% cohesive failure). Verification of sealant cure and adhesion is done through the use of “peel adhesion” and/or “H-piece” testing. It is the responsibility of the SG applicator to perform these tests as prescribed in this manual. These procedures are described in greater detail later in the next section.

Reglazing Procedures

Glass breakage occurs during all phases of a construction project and even long after the building is completed. How a system will be reglazed is an important design consideration. The specific procedures will vary from project to project. Following are general guidelines for reglazing.

Reglazing Due to Glass Breakage

The following procedure assumes that a DOWSIL™ Silicone Structural Glazing Sealant was originally used on the project and that the original recommendations are available to the contractor performing the repairs. If this information is not available, please contact your Dow Construction Office.

1. First determine that the existing sealant is well adhered. A peel adhesion test must be performed to confirm that the existing sealant has excellent adhesion (100% cohesive failure) to the frame. If excellent adhesion is not achieved, please contact your Dow Construction Office.
2. Remove all existing damaged glass. Depending on the design, the glass may be removed using a cutting blade or piano wire.
3. Cut away the silicone leaving a thin film (1 to 2 mm) of sealant on the frame. Complete removal of the sealant is not necessary. If complete removal of the sealant is preferred, care must be taken to avoid damage to the finish of the substrate during removal of the sealant.
4. If freshly applied sealant will be applied within 1 hour after cutting the cured sealant, solvent cleaning of the existing silicone surface will not be necessary. Since new silicone sealant fully adheres to cured silicone sealant, no priming is required for silicone sealant to adhere to silicone sealant. If the existing silicone is solvent cleaned, allow the absorbed solvent to evaporate before application of the new sealant.
5. If the existing sealant is completely removed down to the frame, solvent cleaning of the frame will be required. Primer may also be required. Please refer to the original Dow approvals for the project.
6. Clean and prepare the glass or panel before setting on the frame. Replace the spacer if necessary and set the glass. Install temporary fasteners to allow the glass to remain attached as the sealant cures. Mask the joint if necessary.
7. Fill the SG joint with a fresh bead of sealant. Tool the joint and remove the masking if used. Please refer to the sealant application procedures described earlier in this section. Inspect the joints to ensure that they are completely filled and properly tooled.
8. After the sealant has fully cured, the temporary clips may be removed. One-component sealant cure may take 1 to 4 weeks or longer depending on the joint geometry, temperature and humidity.
9. Quality control guidelines described later in this manual must be completely followed.

Some SG systems do not allow easy reglazing of the damaged glass. These systems are designed to have the entire curtainwall unit, including the frame, removed and replaced together. In such instances, follow the sealant application guidelines for new factory glazing which is described earlier in this section.

In some instances, the structural joint cannot be accessed once the glass has been set. With systems such as this where the frame cannot be removed and the glass must be set in the field, it is acceptable to use the following reglazing procedure. Please consult with your Dow Technical Service Engineer prior to using this reglazing procedure.

1. Remove the damaged glass and prepare the substrate as described in steps 1 through 7 above in section "Surface Preparation and Sealant Application".
2. Apply sealant directly to the frame. Enough sealant must be applied to comfortably overfill the SG joint once the glass is set on the frame. The glass must be set within 10 minutes of sealant application. The glass must compress the sealant so it sufficiently fills the joints with minimal air entrapment or bubbles. If possible, the joint surface should be tooled.

Reglazing Due to System Failure

Although complete system failure of a structural glazed system is very rare, there are situations, particularly with older SG technology or linked to quality problems not associated with the structural silicone, where an entire SG façade must be replaced. Because these projects can be very complex, please contact your Dow Technical Service Engineer during the investigation and planning phase of the remediation.

Quality Control Test Procedures

General Considerations

Quality Control is one of the most important elements of a successful structural glazing project and is the primary responsibility of the SG applicator. This section of the manual should be fully understood and continually reviewed by the sealant user. The procedures and recommendations made in this section are the foundation of a comprehensive quality control program. In the Documentation section of this manual, Dow provides quality control logs which you can use for the development of a comprehensive quality control program by the sealant user. Dow will assist you in the development of a comprehensive quality control program specifically for your organization. Dow will also audit a production facility and make recommendations for improvement if necessary. Later in this section is a best practices guide for SG production facilities.

During production, periodic quality control should be performed on DOWSIL™ 993 Structural Glazing Sealant produced through the two-component dispensing equipment. These test procedures help to ensure the sealant is being properly mixed at the correct ratio. These tests and their recommended frequency are shown in the following table:

Sealant Production QC Test	Frequency of Test		
	After Each Pump Start-Up	After Each Container Change	Diagnostic Investigation
Glass Test	Required ¹	Required ¹	Required
Butterfly Test	Required ¹	Required ¹	Required
Snap Time Test	Required	Required	Required
Mixing Ratio Test	Not Required	Not Required	Required

¹ Either the glass test or butterfly test must be performed at the scheduled frequency. It is not required that both tests be performed.

Although DOWSIL™ 993 Structural Glazing Sealant - Black is most commonly used, the sealant is also available in white, grey or custom colors for special projects. In such cases, performing tests such as the glass test and butterfly test will be more difficult. Please contact your Dow Technical Service Engineer for specific quality control recommendations for grey or white DOWSIL™ 993 Structural Glazing Sealant.

Glass Test

The Glass Test is a procedure used to evaluate the mix of DOWSIL™ 993 Structural Glazing Sealant. This test is performed each time a pump starts-up and after either the curing agent or base containers are changed. The purpose of this test is to determine whether the two-component dispensing equipment is adequately mixing the sealant base and curing agent.

For standard DOWSIL™ 993 Structural Glazing Sealant – Black, the sealant base is white and the curing agent is black. When properly mixed, the finished sealant is uniform black, with no grey or white streaks. Improper mix can be the result of a damaged check valve, a clogged hose, a clogged mixer, etc. Regular equipment maintenance will help to ensure proper sealant mixing. Please consult with your dispensing equipment manufacturer for maintenance guidelines. If grey, white or custom colored DOWSIL™ 993 Structural Glazing Sealant is being used, please contact your Dow Technical Service Engineer for recommendations.

To perform the Glass Test Method, apply a bead of sealant to a clean, clear glass sample which is approximately 10 cm x 10 cm. Place another clean, clear glass sample on top of the silicone, pressing the two pieces of glass together. Please refer to the diagram on this page. The resulting sandwiched sealant

should then be visually inspected for grey or white streaks. The sealant should appear completely uniform and black. If results are negative, perform the test again after additional material is processed through the machine. If the results are negative again, equipment maintenance may be required. If additional assistance is required, please contact your Dow Technical Service Engineer.

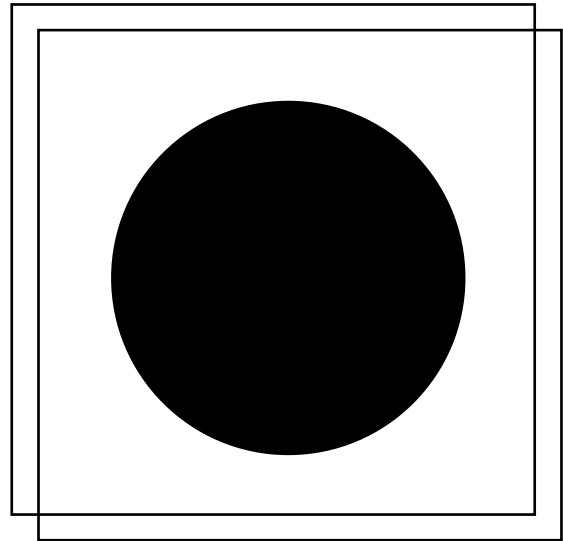

Glass Test: Proper Mixing

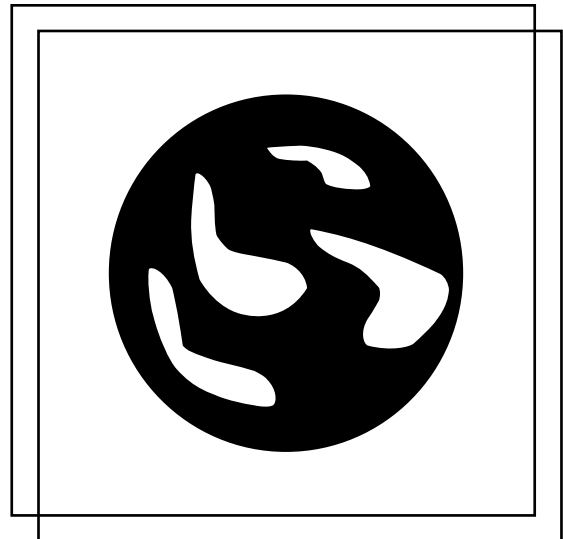

Glass Test: Insufficient Mixing



Butterfly Test

The Butterfly Test is a procedure that is similar to the Glass Test. This test is performed at each pump start-up and after either the curing agent or base containers are changed. The purpose of this test is to determine whether the two-component dispensing equipment is adequately mixing the sealant base and curing agent. For standard DOWSIL™ 993 Structural Glazing Sealant – Black, the sealant base is white and the curing agent is black. When properly mixed, the finished sealant is uniform black, with no grey or white streaks. Improper mix can be the result of a damaged check valve, a clogged hose, a clogged mixer, etc. Regular equipment maintenance will help to ensure proper sealant mixing. Please consult with your dispensing equipment manufacturer for maintenance guidelines.

If grey, white or custom colored DOWSIL™ 993 Structural Glazing Sealant is being used, please contact your Dow Technical Service Engineer for recommendations.

Following is the procedure for performing a Butterfly Test:

1. Fold a sheet of stiff, white A4 paper in half.
2. Apply a bead of sealant to the fold in the paper.
3. Press the sheet of paper together compressing the sealant into a thin film.

Pull the paper apart and visually inspect the sealant for indications of poor mix.

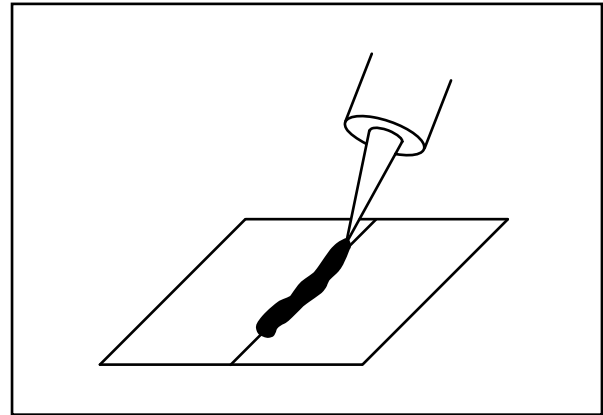

Apply Sealant to Folded Paper

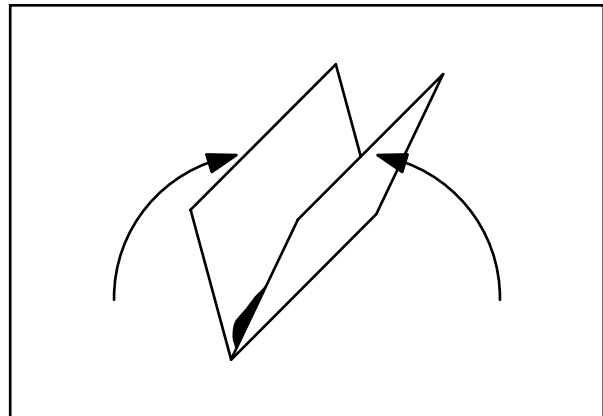

Press Together

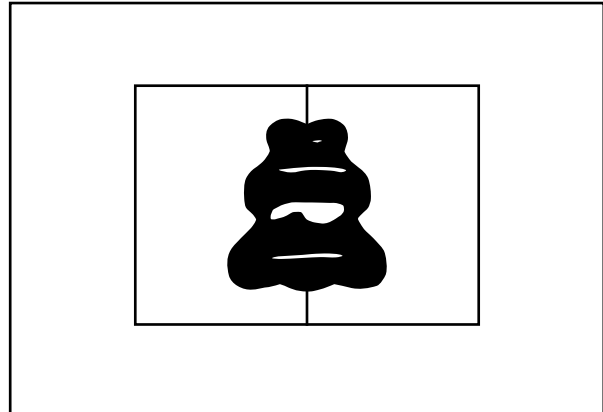

Insufficient Mixing

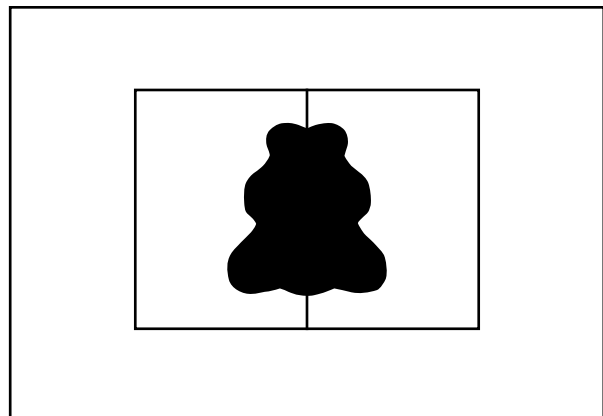

Proper Mixing



Snap Time Test

Once proper mixing of the sealant is established by the Glass Test and/or Butterfly Test, a Snap Time Test must be performed. This test is performed each time a pump starts-up and after either the curing agent or base containers are changed. The snap time test helps to determine if the mix ratio is correct and whether the sealant is curing properly. Mixed sealant will handle like a one-component sealant until the chemical reaction between the base materials and curing agent begins to take place. The sealant will in a matter of minutes begin to “snap” and begin to show elastomeric or rubber properties.

Following is a procedure for the Snap Time Test:

1. Fill a small container with mixed DOWSIL™ 993 Structural Glazing Sealant.
2. Place a small stick or spatula into the sealant. Record the time.

Every few minutes, pull the stick out of the sealant. Do not stir or agitate the sealant. As the sealant becomes more cured, the sealant will become stringy. Once the sealant tears cohesively and snaps back once it is pulled, this is the “snap time”. Record this time.

The Snap Time Test will vary depending on temperature and humidity. Higher temperatures and higher humidity will cause the sealant to snap faster. Colder temperatures and lower humidity conditions will slow the snap time. On the following page is a figure which shows the effect of temperature on snap time. Snap time will also vary from tester to tester depending on how the results are interpreted. Also, there will be variation from lot to lot of material and as the sealant ages. Highly unusual snap time values could be an indication of a problem with the pump. The most important determination from snap time is that the sealant does cure. If the sealant does not cure, then further investigation is required.

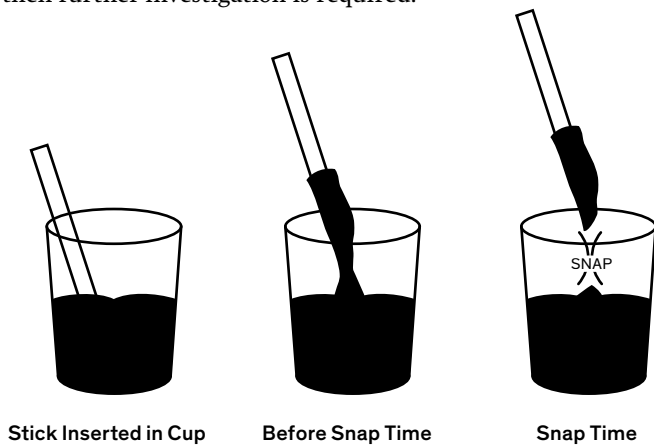

Mixing Ratio Test

The Mixing Ratio Test is not a test that is required by Dow as a daily test. This test is useful to determine whether the sealant is mixing at the recommended ratio of 10 to 1 by weight. Most two-component silicone dispensing machines provide a set of valves which allow the mixing ratio to be checked. Following is a procedure to perform the Mixing Ratio Test:

1. Pressure valves must be adjusted in such a way that the pressure is equalized for both components.
2. Hold a disposable cup underneath each valve outlet on the pump. Open the valve for 10 seconds or at least 3 strokes of both the base and curing agent pumps.
3. Weigh the two cups, minus the weight of the cup itself. The weight ratio between the two-components should be between 9 to 1 and 11 to 1.

It has been the experience of Dow that this test is not reliable as a daily quality control test. It is a useful test if there are concerns with the mix of the sealant or the snap time. This test method is a very good diagnostic test and along with the glass test or butterfly test and the snap test, should be useful in the investigation of equipment problems. Dow Technical Service Engineers are available to assist you if there is concern with mixing or cure of DOWSIL™ 993 Structural Glazing Sealant.

Typical Snap Time vs. Temperature for DOWSIL™ 993 Structural Glazing Sealant

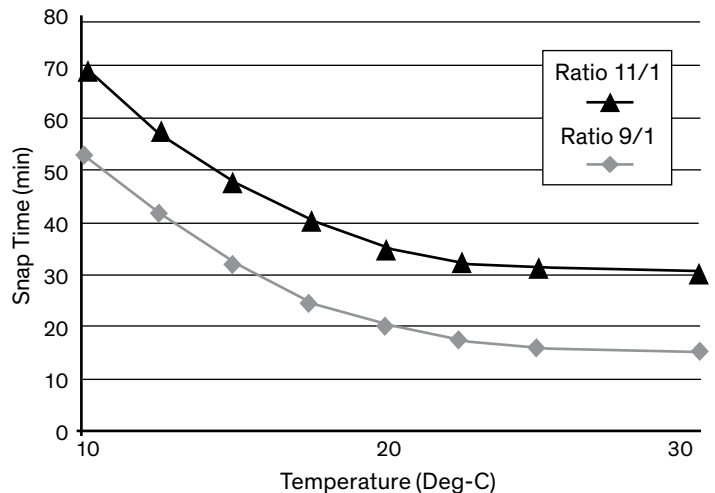

Adhesion and Cure Quality Control Tests

The following adhesion and cure quality control tests individually and together are the best means to determine whether you will have a successful structural glazing project. Each test is valuable in its own way and must be considered as part of your comprehensive quality control program. Dry Peel adhesion testing is recommended as the daily test to verify sealant adhesion. For anodized aluminium substrate, the initial adhesion peel must be reproduced after 15 minutes water immersion. H-piece testing is recommended as a test to verify proper cured sealant properties. Deglazing is a procedure to verify proper sealant adhesion, cure and quality in actual production units.

Dow requires the adhesion and cure quality control tests be performed by the sealant user at the frequency recommended in the following chart:

Sealant Adhesion and Cure QC Test	Frequency of Test		
	After Each Pump Start-Up	After Each Container Change	After Each Substrate Change
Peel Adhesion Test Dry	Required	Required	Required
Peel Adhesion Test Wet	Required (only for anodized aluminium)	Required (only for anodized aluminium)	Required (only for anodized aluminium)
H-Piece Test	Alternate to Peel Adhesion Test	Required ¹	Alternate to Peel Adhesion Test
H-Piece Test Wet	Alternate to Peel Adhesion Test Wet (only for anodized aluminium)	Required ¹ (only for anodized aluminium)	Alternate to Peel Adhesion Test Wet (only for anodized aluminium)
Deglaze Test	Not Generally Required ²	Not Generally Required ²	Not Generally Required ²

¹H-Piece testing after each container change may not be required by Dow in some cases
²Deglaze testing is a valuable test that should be included in every comprehensive quality control program. Deglaze testing may be required for specific projects or if special warranties are requested.

Peel Adhesion Tests

Peel adhesion test is the most effective daily test to verify sealant adhesion to a substrate. This simple screening test should be used as the daily test to verify adhesion of sealant to a substrate. This test should be performed on all substrates to which the sealant is expected to have adhesion at the following intervals:

- After each pump start-up or after extended breaks
- After a change of the curing agent or base container
- For each new lot of substrate

Following is a description of the peel adhesion test:

1. Clean and prime the substrate as recommended by Dow.
2. Place a piece of polyethylene sheet or bond breaker tape across the flat surface.
3. Apply a bead of sealant and tool it to form a strip approximately 20 cm long, 1.5 cm wide and 6 mm thick. At least 4 cm of the sealant should be applied over the polyethylene sheet or bond breaker tape.

4. It is best to imbed a wire mesh halfway within the body of the sealant. For best results, solvent clean and prime the screen to ensure good adhesion to the wire mesh. If wire mesh is not available, reliable results can still be achieved.
5. After sealant cure, grasp the 4 cm tab of sealant which overlays the polyethylene sheet. Pull the sealant at a 180° angle. Peel back only 1 to 2 cm of sealant leaving the remainder in place for additional testing.
6. If the sealant tears within itself and remains fully bonded to the substrate, this is called “cohesive failure”. 100% cohesive failure is desirable since this indicates that the strength of adhesion is greater than the strength of cohesion.
7. If the sealant releases from the substrate, the sample indicates 100% adhesive failure (or 0% cohesive failure). Since sealant adhesion develops over time, repeat the test after an additional 24 hours of cure. Continue until 100% cohesive failure is achieved. If adhesion does not develop as expected, contact your local Dow Construction Office.

For anodized aluminium and when 100% cohesive failure is recorded in dry conditions, place the initial peel test under water immersion for 15 minutes at room temperature. Take out the sealant from the water and start again peel testing procedure. 100% cohesive failure in wet conditions is required. If adhesion does not develop as expected, contact your local Dow Construction Office.

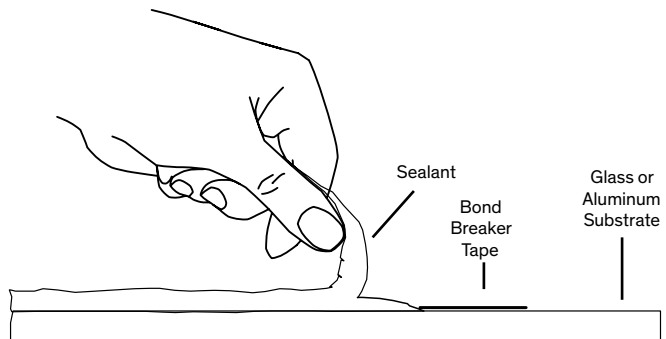

Peel Adhesion Test: Cohesive Failure

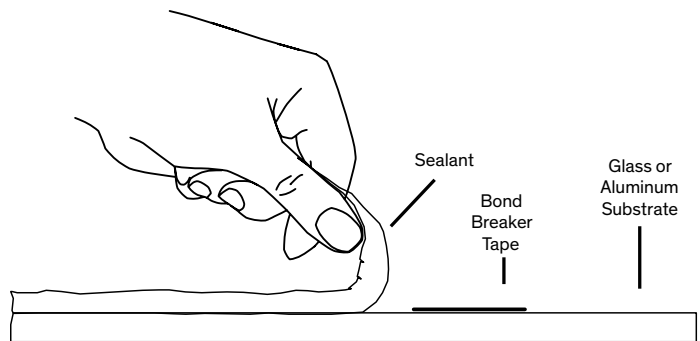

Peel Adhesion Test: Adhesive Failure

Following are some additional recommendations for peel adhesion testing:

- Peel adhesion tests must be run on production samples from the exact same lot of substrate or profile.
- The substrate should be cleaned exactly the way the production units are cleaned.
- The peel adhesion samples must be cured in the same temperature and humidity that the production units are stored.
- Samples should be tested periodically, for example 1, 2, 3 days cure for DOWSIL™ 993 Structural Glazing Sealant. Testing can conclude once the peel adhesion test shows full adhesion or 100% cohesive failure. For DOWSIL™ 895 Structural Glazing Sealant, peel adhesion tests should be performed at 7 day intervals.
- For the wet adhesion test required for the adhesion on anodized aluminium substrate, no specific reconditioning required before the peel test.
- Local authorities may require specific and additional testing procedures such as: Once samples achieve full adhesion, immersed them in room temperature water for one day to seven days and test them again for cohesive failure.

Important: SG production units can only be shipped to the jobsite once full adhesion has been verified by successful peel adhesion tests under dry and wet conditions (for anodized aluminium). 100% cohesive failure required.

H-piece Test

The H-piece test is the primary test used to evaluate sealant cure properties. This test should be performed once for every combination of base and curing agent. If a container is changed, an H-piece test should be used to confirm that the sealant cure properties are acceptable. In some instances, Dow may not require H-piece testing as a part of a comprehensive quality control program if other procedures such as peel adhesion and deglaze testing are performed at an appropriate frequency and if local standards and regulations do not require H-piece testing. The H-piece test can be used as a daily adhesion quality control test but because the peel test is less complicated to perform, the peel test is the recommended daily adhesion quality control test.

Every time a container is changed, four H-piece test samples should be produced. Samples should be made using actual production substrates (aluminium profile and glass, typically). The substrates should be cleaned and primed in the same manner as production units are prepared. The test samples should be stored in the same temperature and humidity environment as the actual production units.

The first H-piece sample should be tested when production units are to be shipped to the jobsite. The peel adhesion tests should be used to verify full adhesion (100% cohesive failure). Full adhesion typically occurs after 1 to 3 days of cure for DOWSIL™ 993 Structural Glazing Sealant and 1 to 4 weeks for DOWSIL™ 895 Structural Glazing Sealant, depending on joint geometry, temperature and humidity. DOWSIL™ 895 Structural Glazing Sealant must have full adhesion and cure in the actual

production units before the units are shipped to the jobsite. If properly cured, the sealant should have a minimum strength of 0.70 MPa with 100% cohesive failure. If results are not acceptable, a second H-piece is available for additional testing.

When dry results are acceptable or when H-piece test is used as an alternate to Peel test for anodized aluminium, wet testing must also be operated after 15 minutes water immersion at room temperature. Full adhesion (100% cohesive failure) and minimum strength of 0.70 MPa must be achieved in dry and wet conditions.

Below is a detail of showing the dimensions of an H-piece sample:

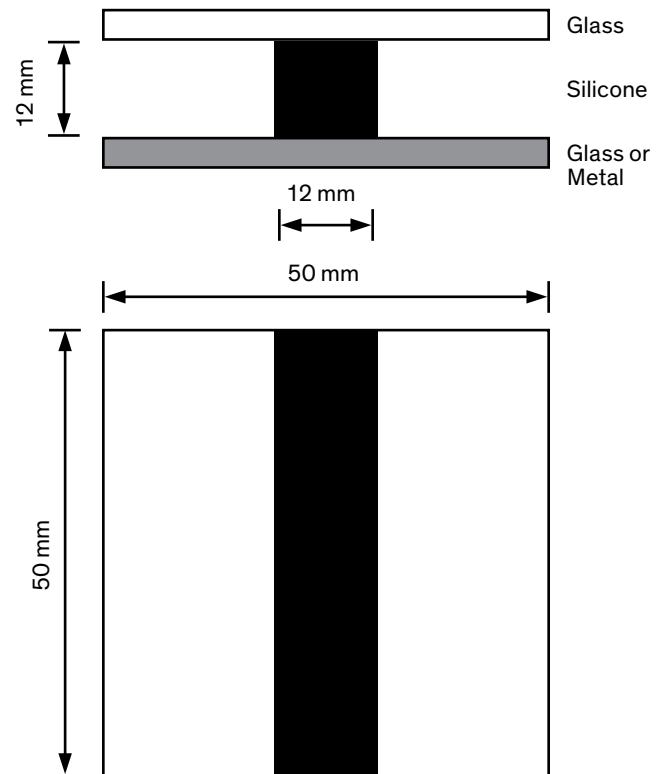

Test samples can be prepared using a wooden block which has been cut to allow a cavity to be filled with sealant in the dimension shown. The wooden block should be pre-treated with a soap solution or paraffin wax to provide a bondbroken surface for the sealant. Alternatively, a polyethylene bondbreaker tape can be applied to the wooden surfaces to contact the sealant. A polyethylene U-channel specifically designed for this test method can also be used. Two H-piece samples should be produced for every combination of curing agent and base used in production. Test samples should be stored in the same conditions as the actual production units. One sample should be tested at the same time that production units are to be shipped to the jobsite. Separately, peel adhesion testing should verify full adhesion (100% cohesive failure) at the same time.

H-piece samples can be tested with either a tensiometer or through the use of a “Roman Scale”. A Roman Scale as represented below will allow the silicone user to test sealant cure and adhesion with a low cost piece of equipment.

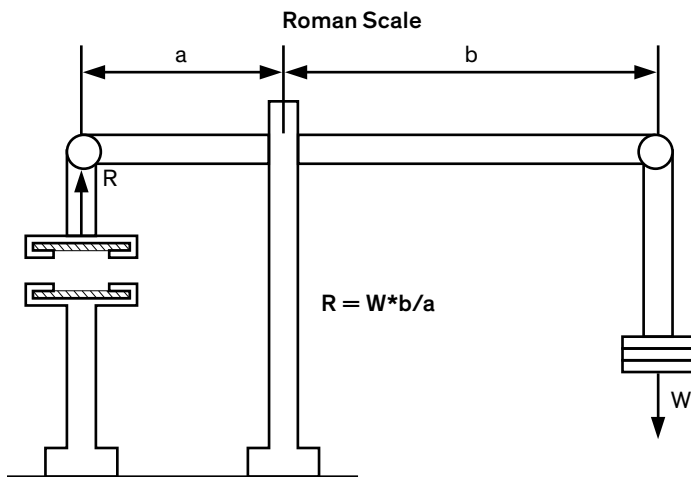

The weight applied to the silicone joint is equal to the weight (W) on the Roman Scale plate times the ratio of b/a. The H-piece sample should be tested to rupture. The tensile strength at rupture should be a minimum of 0.70 MPa. This value corresponds to strength of $12 * 50 * 0.7 = 420$ N applied to the test piece. This strength corresponds to a load of 42 kg. If the Roman Scale is designed to have a b/a ratio of 10, a weight of 4.2 kg should be applied to the plate (W).

The load should be applied for a maximum of 10 seconds with no adhesive or cohesive failure of the H-piece. If no rupture occurs, incrementally add 0.5 kg to the scale until the H-piece ruptures. Record the load at rupture and percent cohesive failure observed on the test sample.

In absence of local standards, H-piece testing of either DOWSIL™ 895 Structural Glazing Sealant or DOWSIL™ 993 Structural Glazing Sealant should meet a minimum strength of 0.70 MPa with 100% cohesive failure to actual production substrates. For anodized aluminium, same criteria must be achieved after the 15 minutes water immersion at room temperature. Results of H-piece testing should be recorded in a quality control log. A sample copy of an SG Quality Control Log is included in the Documentation section of this manual.

Deglaze Test

Deglazing is a method of quality inspection used to confirm sealant adhesion, joint fill and quality in actual SG production units. Deglazing includes complete detachment of a structurally glazed panel from a frame. Once the glass or panel is removed, the silicone sealant is inspected for cure, mix, uniformity of fill, lack of bubbles or air entrapment and most importantly, to verify sealant adhesion. Deglazing is very useful to production personnel as a form of feedback on their performance. Production personnel should be present during the inspection.

Included in the Documentation section of this manual is a deglaze inspection form. During inspection, the following elements should be evaluated:

- Measured dimension of the structural bite. The minimum structural bite as determined in the project review must be satisfied. An underfilled joint may affect the performance of the SG system.
- Measured dimension of the glueline thickness.
- Adhesion of the structural sealant to the substrate and panel. Sealant must achieve full adhesion (100% cohesive failure) to all substrates.
- Sealant uniformity of cure and sealant mix.
- Lack of air entrapment and bubbles in the sealant.

Any deficiencies observed should be reported in the SG Quality Control Log.

Dow does not require this test method as a standard quality control procedure. Nevertheless it is a good practice that should be incorporated in a comprehensive quality control program. For special warranties and certain projects, Dow may require this procedure in the quality control program.

Deglazing should be performed as a regular quality control procedure in a production operation. This test can be performed randomly on any production sample. Additionally, this test should always be performed on units where the glass is damaged or for some other reason needs to be replaced. When replacing the glass, a deglaze inspection can easily be performed. Glass can be effectively removed using a knife or piano wire. It is best to cut the sealant mid-way in the joint so that enough sealant is left on the frame and panel to allow an adhesion test to be performed. A peel adhesion test, as described earlier in this manual, can be performed on the remaining sealant.

Following is a recommended frequency for deglaze testing to be performed on a project:

1. First Deglaze – 1 unit out of first 10 units manufactured (1/10)
2. Second Deglaze – 1 unit out of next 40 units manufactured (2/50)
3. Third Deglaze – 1 unit out of next 50 units manufactured (3/100)
4. Through remainder of project, 1 unit of every 100 units manufactured

For further assistance, please contact your Dow Technical Service Engineer.

Documentation

The sealant user is responsible for developing proper quality control documentation for their project. Dow provides in the following pages, sample quality control logs that can be used on their own or as a model for a customized quality control manual. At completion of a project, the quality control logs must be provided to Dow if a warranty is requested. Dow recommends that project documentation be retained for at least the length of the warranty. These documents should be available to Dow or local officials if requested.

A comprehensive quality control manual for an SG project should include the following:

- SG details that were reviewed and approved by Dow
- Dow Project Checklist approval letter(s)

- Project substrate and materials descriptions and specifications
- Dow adhesion and compatibility approval letter(s)
- In-house SG production and quality control procedures
- Completed sealant production quality control logs with glass test, butterfly test, snap time test and mix ratio test results
- Completed sealant adhesion and cure quality control logs with peel adhesion test dry and wet conditions, H-piece test and deglaze test results
- Traceability documentation which allows each production unit to be precisely correlated to a specific date, time and location of production. All production units must be numbered so that they can be specifically linked to the quality control logs. The position of each panel on the building should be marked on the elevation drawing so that it can be easily identified if required. This traceability documentation is critical in the event that a problem needs to be investigated on a project.

Dow will assist you in the development of a comprehensive quality control program. During a Production and Quality Control Audit, your comprehensive quality control program will be evaluated.

Production and Quality Control Audit

Dow will audit the structural glazing production and quality control operations of any user of DOWSIL™ Structural Glazing Silicone Sealants. During this audit, the sealant user's production operations, quality control procedures and documentation will be evaluated. Dow will provide recommendations for improvement and establish an action plan with the SG applicator. Following are some of the important elements that Dow will be evaluating during an audit:

Production Facility Operations and Safety

- Cleanliness of the production facility
- Production facility temperature and humidity
- Proper sealant storage and handling
- Properly operating and well maintained sealant dispensing equipment
- SG Design and material approved by Dow
- Proper substrate handling
- Compliance with Dow recommended sealant application procedures: two-cloth cleaning method, priming, sealant application, tooling, etc.
- Storage and handling of production units
- Compliance with reasonable safety procedures including safe handling of flammable materials and use of personal protective equipment

Quality Control

- Compliance with Dow sealant production quality control procedures: glass test or butterfly test, snap time test, mix ratio test

- Properly completed sealant production quality control log
- Compliance with Dow adhesion and cure quality control procedures: peel adhesion test, H-piece test, deglaze test
- Properly completed adhesion and cure quality control log
- Traceability documentation in accordance with Dow recommendations
- Commitment by management to train personnel and implement a comprehensive quality control program.

Maintenance and Repair

Structural glazing systems which utilize DOWSIL™ Structural Glazing Silicone Sealants in general do not require maintenance. DOWSIL™ silicone sealants are inherently resistance to ultra-violet light, moisture, ozone, acid rain and other natural elements. DOWSIL™ silicone sealants have been used in construction applications for over 40 years and examination of silicone sealants over this period of time has shown little evidence of degradation of performance or physical properties. Therefore, it would be expected that the current range of silicone sealants would also exhibit similar long-term performance provided that the correct product has been specified and that the sealants have been applied in accordance with Dow recommendations.

Periodic inspection of the sealant and structural glazing system is recommended. Some local regulations may require periodic inspection by an independent party. There is no standard guide for frequency of inspection but a typical inspection frequency would be as follows:

- 1st Inspection - Upon completion of the installation
- 2nd Inspection – 1 to 2 years after installation
- 3rd Inspection – 5 years after installation followed by subsequent 5 year inspections

Method of inspection may consist of:

1. Visual inspection of structural glazing system and structural silicone sealants. Observe any indication of sealant adhesion loss or sealant physical property change.
2. Hand pressure on accessible sealant joints to verify sealant adhesion
3. Use formal SG inspection procedures such as described in ASTM International Standard C1394.

Although silicone sealants generally do not require maintenance, silicone sealants may be subject to mechanical damage such as vandalism or bird attack. Damaged areas can be repaired with the use of new silicone sealant. Please contact Dow for further recommendations.

Silicone sealants may also show changes in appearance resulting from collection of atmospheric pollution, dirt or other airborne contaminants. A change of color on the sealant surface may appear. This change does not affect the performance of the sealant. In such cases, contaminants can normally be removed with the use of water and a mild detergent. Avoid abrasion which could damage the sealant.

Please contact your Dow Technical Service Engineer if further assistance is required.

European SG Project Checklist

A European SG Project Checklist must be completed for each project. The European SG Project Checklist can be accessed

at consumer.dow.com/construction. Please contact your local Dow Construction Office for more information.

Project Name and Location			
Project Start Date dd/mm/yyyy		Estimated Completion Date	
Project Description			Sq. M of SG Facade:
SG System Type:	4-sided <input type="checkbox"/>	2-sided <input type="checkbox"/>	SG System Manufacturer:
Technical Contact:	Email:		
Phone:	Fax:		
Architect:	Consultant:		
General Contractor	IG Manufacturer:		
DOWSIL™ Sealant(s) used*: 993 <input type="checkbox"/> 895 <input type="checkbox"/> 791 <input type="checkbox"/> 756 <input type="checkbox"/> Other <input type="text"/>			
Largest Glass Height (m)		Shortest Glass Height (m)	
Largest Glass Width (m)		Shortest Glass Width (m)	
Design Windload (Pa)		Deadload Support (Y/N)	
Other Loads (Pa)		Slope Glazing Angle from Horizontal	
Spandrel Glass <input type="checkbox"/>	Vision Glass <input type="checkbox"/>	Laminated Glass <input type="checkbox"/>	Insulating Glass <input type="checkbox"/>
Total Thickness of Outer Pane (mm)		Total Thickness of Inner Pane (mm)	
DOWSIL™ IG Sealant Used*: 3362 <input type="checkbox"/> 3793 <input type="checkbox"/>		IG Joint Dim. (mm x mm)	
Profiles Exposed to Outside Temp. (Y/N)		Max. Profile Temp. (°C)	
Aluminium or Steel Profile?		Max. Glas Temp. (°C)	
Temperature During Production (°C)			
Proposed Structural Bite Dimension (mm)		Proposed Glueline Thickness (mm)	
Profiles Tested/Approved by Dow? (Y/N)		Document ID Number:	
SG Details Have Been Sent or Will Be Sent to Dow (Y/N)		Name/Number if a Standard SG System	
Additional Comments:			

*DOWSIL™ 993 Structural Glazing Sealant, DOWSIL™ 895 Structural Glazing Sealant, DOWSIL™ 791 Silicone Weatherproofing Sealant, DOWSIL™ 756 SMS Building Sealant, DOWSIL™ 3362 Insulating Glass Sealant, DOWSIL™ 3793 Insulating Glass Sealant

SG Project Testing Submission

Sample information should be entered through Dow COOL which can be accessed at consumer.dow.com/construction.

Please contact your local Dow Construction Office for more information and access. The following information is required with each SG project testing submission:

Project Name and Location:				
DOWSIL™ Sealant(s) to be tested for this project*:	993 <input type="checkbox"/>	895 <input type="checkbox"/>	791 <input type="checkbox"/>	756 <input type="checkbox"/> Other <input type="text"/>
Cleaning Solvent(s)				
	Type (i.e. Anodized)	Supplier	Color	Lot Number
Profile Description				
Profile Description				
Profile Description				
	Manufacturer	Type (i.e. Coated)	Name/Brand	Color
Glass Description				
Glass Description				
	Manufacturer	Description	Name/Brand	Color
Other Substrate				
Other Substrate				
	Manufacturer	Description	Supplier	Name/Brand
Accessory Material				
Accessory Material				
	Description of sample type and size to be submitted to Dow			
	Aluminium or Steel Profile	4 pieces approximately 20 cm long		
	Coated, Enameled or Previously untested glass	3 pieces approximately 20 cm x 15 x cm		
	Accessory Material (structural spacer, gaskets, tapes, setting blocks, etc.)	2 piece or 2 lengths of approximately 10 cm		

Samples should be sent to the following address:	<p>Dow Silicones Belgium S.P.R.L Attention: Sealants Testing Lab rue Jules Bordet, parc industriel zone C 7180 Seneffe, Belgium</p>	emeai.cool@dow.com
--------------------------------------------------	----------------------------------------------------------------------------------------------------------------------------------------------------------------------------	--------------------

*DOWSIL™ 993 Structural Glazing Sealant, DOWSIL™ 895 Structural Glazing Sealant, DOWSIL™ 791 Silicone Weatherproofing Sealant, DOWSIL™ 756 SMS Building Sealant

Sealant Adhesion Quality Control Log (Peel Adhesion Test)

Company Name and Location:											
Project Name and Location:											
Dispensing Pump Type and Location:											
Cleaning Solvent:					Primer:						
Substrates:					Primer Lot Number:						
Date	Time	Temp. & Humidity	C/A Lot Number	Base Lot Number	Peel Adhesion Test (% Cohesive Failure)						Tester
					Day 1		Day 2		Day 3		
					Dry	Wet	Dry	Wet	Dry	Wet	

Sealant Adhesion and Cure Quality Control Log (Deglaze Test)

Company Location:	
Project Name and Location:	
Dispensing Pump Type and Location:	
Frame Description:	Cleaning Solvent:
Primer:	Primer Lot Number:
Base Lot Number:	Curent Agent Lot Number:
Glass Description:	Frame Number:
Sealant Application Date:	Deglaze Test Date:
<p><u>Results and Observations:</u></p> <p>Measured SG Bite (Glass): _____ Measured SG Bite (Frame): _____</p> <p>Measured Glueline Thickness: _____</p> <p>Joint Fill: _____</p> <p>Sealant Mix: _____</p> <p>Air Entrapment or Bubbles: _____</p> <p>Sealant Adhesion to Frame: _____</p> <p>Sealant Adhesion to Glass or Panel: _____</p> <p>Sealant Cure Uniformity: _____</p> <p>Other Observations: _____</p>	

Contact Us

Dow is collaborating with industry professionals around the world to develop solutions to improve the energy efficiency of buildings for a more comfortable environment. Learn more about Dow's full range of High Performance Building solutions by visiting us online at consumer.dow.com/construction.

Dow has sales offices, manufacturing sites and science and technology laboratories around the globe. Find local contact information at consumer.dow.com/ContactUs.

Images: dow_41057982324, dow_40355048103, dow_42804421207

LIMITED WARRANTY INFORMATION - PLEASE READ CAREFULLY

The information contained herein is offered in good faith and is believed to be accurate. However, because conditions and methods of use of our products are beyond our control, this information should not be used in substitution for customer's tests to ensure that our products are safe, effective and fully satisfactory for the intended end use. Suggestions of use shall not be taken as inducements to infringe any patent.

Dow's sole warranty is that our products will meet the sales specifications in effect at the time of shipment.

Your exclusive remedy for breach of such warranty is limited to refund of purchase price or replacement of any product shown to be other than as warranted.

TO THE FULLEST EXTENT PERMITTED BY APPLICABLE LAW, DOW SPECIFICALLY DISCLAIMS ANY OTHER EXPRESS OR IMPLIED WARRANTY OF FITNESS FOR A PARTICULAR PURPOSE OR MERCHANTABILITY.

DOW DISCLAIMS LIABILITY FOR ANY INCIDENTAL OR CONSEQUENTIAL DAMAGES.

®™ Trademark of The Dow Chemical Company ("Dow") or an affiliated company of Dow

© 2018 The Dow Chemical Company. All rights reserved.

86489

Form No. 62-0979-01 J